



INSTRUCTION

VOLUME BUKCET PUMP

VO-8 MODEL No.880132



 **WARNING**

Prior to operating this pump, be sure to read this operation manual for safety. After reading the manual, please keep it at hand any time for your quick reference.

YAMADA CORPORATION

Preface

This instruction manual describes how to use this product properly and what care should be taken, intended that it will serve you well without fault.

Before reading the manual, never operate the product.

Read precautions carefully. Keep this manual handy.

If you find any questions, doubts, or problems in our products, contact our distributors from which you made a purchase or our sales offices described on the back of this manual.

If this instruction manual or caution labels are damaged or lost, buy other ones from which you made a purchase. Save this manual and affix the labels properly.

Contents

1. Purpose of use	2
2. Warning / Caution	2
2-1. Definition of warning and caution	2
3. Precautions	2
4. Name of each section	3
4-1. Packing	3
5. Preparation before use	4
6. How to use	5
7. Maintenance and Inspection	6
7-1. Inspection of malfunctions and troubleshooting	6
7-2. Maintenance and Inspection	6
7-3. Disassembly and Assembly	6
7-4. Exploded parts view / Parts list	8
8. Specifications	9
9. Limited Warranty	10

1. Purpose of use

This machine is a pump to supply oil, in particular, high-viscosity oil to construction machines by using a lever type manual pump. It cannot be used for grease. The machine can keep a large quantity of oil in its cabinet and is most suitable for lubrication work in an outdoor place where no compressor is available. The oil supply port base is a button head type that permits quick and sure lubrication.

2. Warning / Caution

For your safe use

A warning label is affixed on this product and with which precautions are described to call attention to your safe use.

Never fail to observe precautions to prevent any personal injury, physical damage, and accidents



2-1. Definition of warning and caution

WARNING

The following definitions and warning indications are given to specify "warning" and "caution" in this instruction manual.

A warning indication is indispensable to your safe work.

Be sure you understand these indications well before use since the important items to prevent personal injury and physical damage are described on it.

 **Warning:** Given when it is assumed that mishandling may cause death or serious injury.

 **Caution:** Given when it is assumed that mishandling may cause injury and physical damage.

**NOTE : The above labels are intended to improve efficient operation and perform device maintenance.*

3. Precautions

Be sure to observe warning and caution described below since they are very important.

WARNING

- Some types of oil to be used may contain carcinogens. Read the precautions provided by oil manufacturer thoroughly and handle the oil with care.

- Gasoline is a high-volatility fuel. Do not use it to clean the pump in any case. Otherwise, ignition or explosion may be caused.

CAUTION

- This machine is a pump for high-viscosity oil. The machine cannot be used for gasoline, light oil, kerosene, and other solvents.

4. Name of each section



4-1 Packing

The main devices and accessories of this machine are packaged in respective corrugated fiberboard cases. Open the upper part of each corrugated fiberboard case and check the pump assembly and oil tank for damage, and also check whether the package includes all the accessories.

5. Preparation before use

- 1) Install the attached oil resisting hose at the oil discharge port of the pump assembly. Screw the hose completely by hand and tighten it with a spanner so that it may not loosen.
- 2) Loosen the 2 left and right thumbscrews that fix the top-surface cover of the oil tank. Then, shift the cover toward the right. (Fig. 1)
- 3) Wipe the inside of the oil tank with a clean waste cloth and change the applied oil. Take care not to mix sand or dust in the oil.
- 4) Return the cover to their initial positions and tighten the thumbscrews of the cover.
- 5) Tighten the check valve provided on the right side of the pump and operate the handle up/down to bleed air in the pump and hose.
Continue this operation until oil is discharged from the base. (Fig.2)

Fig.1

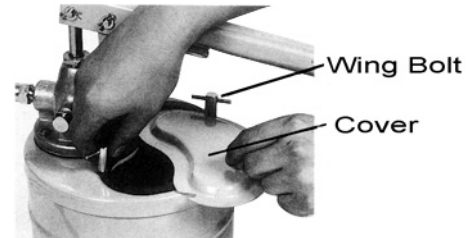
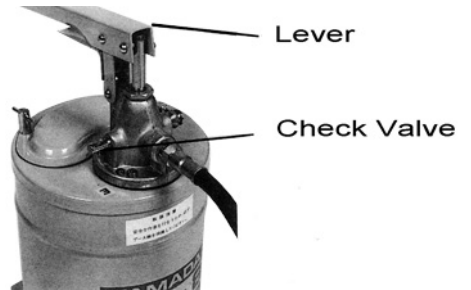

Fig.2



6. How to use

 CAUTION
--

- When operating the handle, do not insert the hand into a clearance between the handle and the handle stopper. An unexpected injury may be caused by nipping.
--

- 1) Wipe the base and the opposite oil supply port base with a clean waste cloth.
- 2) Adjust the base groove to the oil supply port base and set it securely by sliding.
Note that oil leakage may occur if this set status is incomplete.
- 3) Tighten the check valve. If the check valve is loose, the pressure cannot be increased.
- 4) Step on the footboard so as not to move the oil tank and operate the handle up/down slowly to supply oil.
- 5) After completion of the oil supply, loosen the check valve to bleed the internal pressure of the pump and hose. Then, remove the base from the oil supply port base.





 CAUTION
--

If the base is removed from the oil supply port base before the check valve is loosened, oil will be discharged from the pump and hose, thereby contaminating the surroundings.

- 6) After completion of lubrication for all positions, loosen the check valve to bleed the internal pressure of the pump and hose, and hang the base on the base hanger without being contaminated.

7. Maintenance and Inspection

7-1. Inspection of malfunctions and troubleshooting

Symptom	Cause	Contents of inspection and corrective measure
Oil does not come out by operating the handle.	Check whether the check valve is closed. - Check whether oil is used up.	 Check the check valve.  Check and replenish.
Oil comes out but the pressure or flow rate is insufficient.	- The valve is clogged with dust. -The plunger packing is worn away.	 Check and clean the valve.  Check and replace.
Oil comes out from the top of the gland.	- The gland packing is worn away.	 Tighten and replace with a new one.

7-2. Maintenance and Inspection

* The hose is a consumable part. Check it periodically. If any flaw or leak is found, replace it a little early.

7-3. Disassembly and Assembly

WARNING

Gasoline is a high-volatility fuel. Do not use it to clean the pump in any case. Otherwise, ignition or explosion may be caused.

[Disassembling and inspecting the suction section]

- 1) Unscrew the oil resisting hose to remove it.
- 2) Loosen the pan-head screws that fix the pump unit on the oil tank and take out the pump assembly from the oil tank. At this time, the ball spring provided between the pump unit and hose hanger will jump out. Take care not to lose it.
- 3) Fix the main unit on the vice.
- 4) When the suction tube is loosened with a pipe wrench set on this tube, it can be separated from the main unit.
- 5) Fix the suction tube on the vice and unscrew it with the pipe wrench set on the valve adapter.

Then, the valve can be taken out.

- 6) Next, fix the lot on the vice and unscrew it with a spanner set on the ball sheet. Then, the arm-shaped packing, ball, and spring can be taken out. Clean and check each part. If any flaw or abrasion is found, replace it with a new one. In particular, check the sheet surfaces of the valve and ball carefully.
- 7) After checking and replacement, assembly parts as they were taking care about the direction of each part. For assembly, reverse the disassembly procedure.

7-4. Exploded parts view / Parts list

880132 VO-8

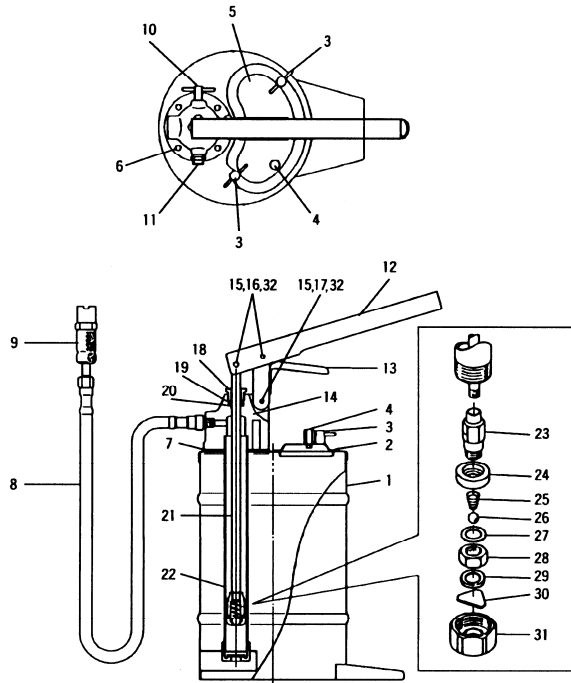

No.	部品番号	部品名称	員数
1	830261	Oil Tank Assy	1
2	770324	Packing	1
3	610619	Wing Bolt	2
4	703146	Knob	1
5	703147	Cover	1
6	602300	Screw	4
7	770325	Packing	1
8	695056	Delivery Hose	1
9	800772	Coupler	1
10	830139	Check Valve	1
11	703148	Nipple	1
12	703149	Lever	1
13	830264	Lever Support Assy	1
14	703159	Body	1
15	680608	Snap Pin	3
16	703574	Pin	2
17	703580	Pin	1
18	580994	Gland	1
19	701755	Washer	1
20	770333	Picking	2
21	707207	Rod	1
22	704833	Suction tube	1
23	703153	Plunger	1
24	770326	L-packing	1
25	703152	Valve Spring	1
26	630321	Ball	1
27	703154	Washer	1
28	703155	Ball Seat	1
29	704835	Washer	1
30	703158	Valve	1
31	704834	Valve Adapter	1
32	631012	Washer	3

800772 Coupler

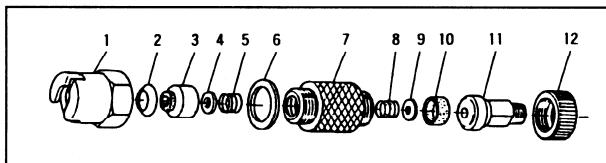

No.	部品番号	部品名称	員数
1	703469	Cap	1
2	703000	Washer	1
3	770311	Packing	1
4	703001	Washer	1
5	703002	Spring	1
6	772676	Packing	1
7	830352	Valve Adapter	1
8	703006	Spring	1
9	703007	Washer	1
10	770312	L-Packing	1
11	703470	Union	1
12	703008	Cap Nut	1

8.Specifications

Product number	Model	Capacity	Height	Weight	Accessory
880132	VO-8	8L	477mm	5.0kg	695056 Delivery Hose 1 800772 Coupler 1

Pump number	Discharge volume*	Exhalation pressure*
850348	20CC / 1 stork	2MPa

The mark * denotes a reference value when machine oil #160, accessory hose, and accessory base are used.

9. Limited Warranty

If an abnormality occurs during normal operation in accordance with the operating instructions and other operating cautions within the warranty period (12 months after date of purchase) that can be attributed to a manufacturing defect, the defective parts of this product will be serviced or the product will be replaced free of charge. However, this warranty will not cover compensation for incidental damage or any malfunction listed below.

1. Warranty period

This warranty will be valid for a period of 12 months after the date of purchase.

2. Warranty

If, during the warranty period, any of the material of the genuine parts of this product or the workmanship of this product is found defective, and is so verified by our company, the servicing cost will be fully born by our company.

3. Exclusion

Even during the warranty period, this warranty does not cover the following.

- 1) Malfunction arising from use of parts other than manufacturer-specified genuine parts
- 2) Malfunction arising from misuse or operating errors, or lack of storage or maintenance care
- 3) Malfunction arising from use with a fluid that may cause corrosion, inflation or dissolution of the component parts of the product
- 4) Irregularity arising from repair made by other than by our firm, our regional office, dealer or authorized service personnel
- 5) Malfunction arising from modification of the product by other than authorized service personnel
- 6) Wear and tear of parts that must be regularly replaced in the course of normal operation, such as packings, O-rings and hose.
- 7) Malfunction and/or damage due to use with incorrect voltage.
- 8) Malfunction and/or damage due to transportation, moving or drop page of the product after purchase
- 9) Malfunction and/or damage due to fire, earthquake, flood or other force majeure
- 10) Malfunction arising from use of compressed air that contains impurities or excessive moisture, or use of gases or fluids other than the specified compressed air
- 11) Malfunction arising from use of excessively abrasive material or of inadequate grease.

Furthermore, this warranty does not cover the rubber parts, or other parts used in this product and its accessories, which are subject to wear in normal operation.

- hoses
- packings
- cords

4. Parts

Parts for this product will be kept available for 5 years after discontinuation of production. Once 5 years have elapsed after close of production, availability of parts for this product cannot be guaranteed.

Manufactured by

YAMADA CORPORATION

INTERNATIONAL DEPARTMENT

1-1-3 Minami Magome, Ohta-ku, Tokyo 143-8504, Japan

PHONE : +81-(0)3-3777-0241

FAX : +81-(0)3-3777-0584

201705 OSA043U